



G002280

System: All Salwico fire alarm systems

Conventional Intrinsically Safe Optical Smoke Detector **EVC-PY-IS**

Part no. N1144

General description

EVC-PY-IS is an intrinsically safe Evolution conventional optical smoke detector.

The detector is equipped with an optical sensor with improved sensitivity to black smoke.

The detector is designed for use in areas with high explosion risk. It is connected to the fire alarm system via an intrinsically safe interface.

To avoid the possible risk of electrostatic charge, the unit must not be cleaned with solvents or charged by rubbing.

Data

Nominal voltage	24 VDC
Working voltage	10–32 VDC
Working current	< 50 μ A
Alarm current	50 mA
Ingress protection	Depending on base
Relative humidity	\leq 95% RH Non-condensing
Temperature range	-20°C to +50°C
Classification	EN54-7:2000
Certification	IECEX ITS 12.0074X ITS09ATEX26418X
Certified according to	CE 0786-CPD-21229
Cover material	ABS
Colour	White
Weight	~120 g

The expected life time of the product is affected by the environment it is mounted in.

The IP class stated is applicable for the connection base and cable glands. The smoke detector head must be open allowing smoke to enter.

For information about suitable base plates, see separate document "Base Matrix".



NOTE!

Do not remove the dust cover from the detector until all polluting (dusty) activities are finished and the area has been cleaned.

Safety data

Max input voltage (U_i)	28 V
Max input current (I_i)	93.3 mA
Max input power (P_i)	0.66 W
Max internal capacitance (C_i)	1 nF
Max internal inductance (L_i)	Negligible
Ex class	Ex II 1 G Ex ia II CT4 Ga -20°C \leq T _a \leq +50°C



WARNING!

Potential electrostatic charging hazard

- Do NOT clean with solvents.
- Do NOT charge by rubbing.
- Clean ONLY with a damp cloth.

Dimensions (mm)

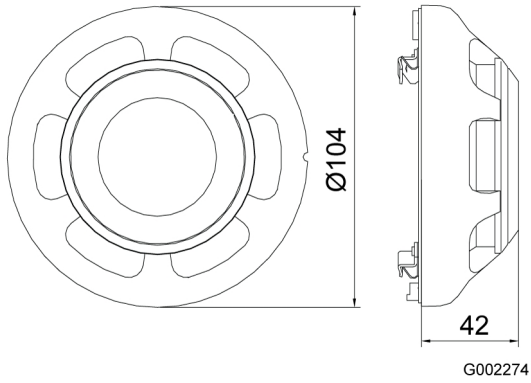

Connection

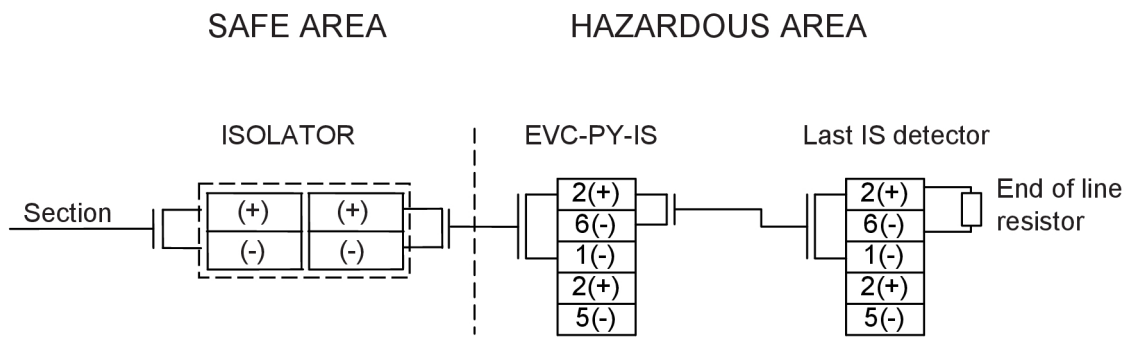

G018723

NITTAN
NITTAN (UK) LTD, HIPLEY STREET, OLD WOKING, SURREY, ENGLAND.
 TEL: +44 (0) 1483 769555 FAX: +44 (0) 1483 756686
 E-MAIL: sales@nittan.co.uk WEBSITE: www.nittan.co.uk

UB-4-IS & EV-SPB-IS BASE INSTALLATION
INSTRUCTION SHEET

A) Apparatus which is unsupervised except that it must not be supplied from nor contain in normal or abnormal conditions a source of potential with respect to earth in excess of 250 volts d.c.

B) Any single channel shunt zero-fault safety barrier or single channel of a dual shunt zero safety barrier certified by any EEC Approved Certification Board to (ExEx) IIC having the following or lower output parameters:-

$U_i = 28V$ $I_i = 93.3mA$
 $I_o = 28V$ $P_i = 0.6W$
 $I_o = 93.3mA$ $C_i = 1\mu F$
 $P_o = 0.66W$

In any safety barrier used the output current must be limited by a resistor 'R' such that $I_o = U_z/R$ or

One of the following isolators:-

- 1) XTL5061 DC Isolator (BAS01ATEX7160)
- 2) MTL4061 Two channel 1 wire & Smoke detector interface (BAS01ATEX7176)
- 3) KFDG-CS-EX-1.54 Isolator (BAS00ATEX7087X)
- 4) KFDG-CS-EX-2.54 Isolator (BAS00ATEX7087X)
- 5) KFDG-CS-EX1-21P Isolator (BAS98ATEX7345)
- 6) KFDG-CS-EX2-22P Isolator (BAS98ATEX7345)

C) Up to 20 Type EVC-PY-IS optical-smoke detectors and type UB-4-IS or EV-SPB-IS Bases (Certificate No. IIS(09)ATEX26418X).

D) An optional RIL circuit, comprising an LED, two diodes and a resistor, may be connected to terminals 2 and 5 of a smoke detector and mounting base. The surface area of the RIL circuit components must be greater than 20mm. The RIL circuit may be considered to

H) A durable label as shown below, to be affixed at the interface of the IS and non-IS circuits.

GROUP	CAPACITANCE IN μF	INDUCTANCE IN mH	OR	L/R RATIO IN $\mu H/\Omega$ min
IIC	0.083	3.05		46
IIB	0.650	9.15		200
IIA	2.15	24.4		360

Origin No.
 Ex Ex IIC 21, T_{amb} = 0°C

I) The electrical circuit in the hazardous area must be capable of withstanding an a.c. test voltage of 500V rms to earth or frame of the apparatus.

© NITTAN (UK) LTD. SUBJECT TO CHANGE WITHOUT NOTICE ENVOYER/USER/ENGINEER/CONTRACTORS/ISSUE 1 (4/19/10) (SHEET 1 OF 1) Description: Base for use with intrinsically Safe EVC-PY-IS Smoke detector

Certified product
 No modifications permitted without reference to notified body.

J) The electrical circuit in the hazardous area must be capable of withstanding an a.c. test voltage of 500V rms to earth or frame of the apparatus.

Part No. 102251 CURRENT ISSUE 1 REMOVE ALL BURRS DIMMS IN MM

DRG. NO. 102251 SHEET OF TITLE EVC-PY-IS SYSTEM CONNECTION DIAGRAM

DATE 04/03/10 ISSUE 1 N/A

NITTAN (UK) LTD.

G018741