



G004188

Address Unit

IC10 WP

Part no. 5200273-00A

System: CS3000, CS4000, TERRA FIRE

General Description

The IC10 WP is an address unit for fire alarm systems. It has been designed for use in damp spaces. This unit allows the connection of different types of devices with closing digital function to the fire alarm system, for example high temp heat detector or sprinkler indication. Please check the specification for the devices to be connected to IC10 WP before use.

An activated alarm is indicated by a red LED on the front of the unit ("Door indication" device not included).

The loop address of the IC10 WP is set by a DIP-switch.

An additional DIP-switch is used to set the type of connected device, see table 2. The device type is shown on the control panel in case of fire or fault.

The IC10 WP is a direct replacement for the discontinued AE-2 series (see replacement table 1 and ID table 2).



Data

Loop nominal voltage	35 VDC
Loop working voltage	22 – 38 VDC
Loop working current	0.2 mA
Minimum sub loop voltage	19 VDC nominal
Output current limit	5 or 15 mA
Output function	Pulsed or steady
EOL (End of line units)	Not included
Ingress protection	IP66
Relative Humidity	At low temperature 95% At high temperature 93% ± 3%
Ambient temperature	-40°C to +70°C

Cable terminals	2.5 mm ²
Cable gland	TET M20 for cable Ø8-13 mm
Material	PC/ABS
Colour	Transparent/RAL7035
Weight	160 g
Certified according to	 2531-CPR-232.1738 DOP no. 6301905

IC10 WP as a Replacement Unit

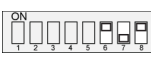
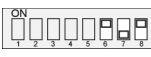
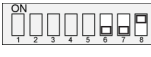
Table 1. IC10 WP replaces the following discontinued products

Part no.	Product	Note	SW2 DIP 6-8
046121	AE-2K-E Address unit	*	
046149	AE-2K Address unit		
046258	AE-2K/I Address unit for door indication		
046259	AE-2K/I Address unit		

* IC10 WP can only be a replacement for AE-2K-E without external 24 VDC.



NOTE!

Physical dimensions will differ between IC10 WP and the replaced products.



Hint!

For type of connected device please refer to table 2. ID set by SW2 DIP 1 to 5.

DIP-Switches

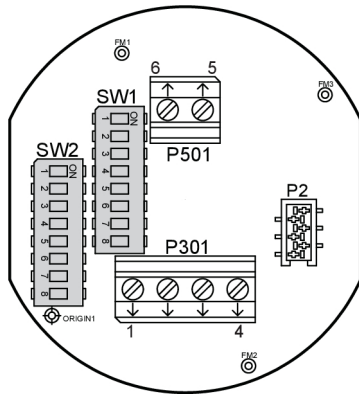

G004177

Figure 1. Location of DIP-switches and connections on the PCB

The following functions are set by the DIP-switches. (Use a pointed tool of suitable size.)

DIP-switch SW1:

The loop address of the unit is set by DIP-switch SW1.

DIP-switch SW2:

- **SW2 DIP 1-5**
The type and function of connected devices are set by SW2 DIP 1 to 5 (using binary system). See table 2 and binary example below.
- **SW2 DIP 6**
Low or high current mode is set by SW2 DIP 6. To activate the high current mode set DIP 6 to ON. Use high current mode only when necessary.
Example: A simple limit switch requires only pulsed measuring type and low current mode, but the HC100 heat detector for example requires steady measuring type and high current mode.



NOTE!

For replacements of AE-2 series by IC10 the SW2 DIP 6 must be set according to table 1.

- **SW2 DIP 7-8**
SW2 DIP 7 is not used and its normal position is OFF.



CAUTION!

SW2 DIP 8 must always be ON!

Binary example SW2 DIP 1-5

DIP settings using binary system to achieve decimal number 9:

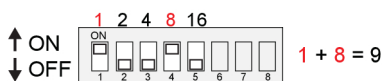

G014279

Table 2. ID set by SW2 DIP 1 to 5

Device type (ID code)	Sensor type (Function)	SW2 DIP 1-5 settings
Heat detector (127/0)	Conventional detector or dry switch ²⁾	
Sprinkler (126/1)	Dry switch, H ₂ O ²⁾	
Sprinkler (125/2)	Dry switch, CO ₂ ²⁾	
Smoke det Ion (124/3)	Conventional detector ¹⁾	
Flame det IR (123/4)	Conventional detector ¹⁾	
Gas detector (122/5)	Conventional detector ¹⁾	
Sprinkler (121/6)	Dry switch, Foam ²⁾	
Sprinkler (120/7)	Dry switch ²⁾	
Flame det UV (119/8)	Conventional detector ¹⁾	
Heat detector (118/9)	Conventional detector ¹⁾	
Door indication (117/10)**	Dry switch or inductive sensor ¹⁾	
Manual call point (116/11)	Conventional MCP ²⁾	
Gas sampling (115/12)	Dry switch ²⁾	
Alarm from external central (114/13)	Dry switch ²⁾	
General alarm (113/14)	E.g. dry switch ¹⁾	
General alarm (112/15)	E.g. dry switch ²⁾	
Smoke det Opto (111/16)	Conventional detector ¹⁾	
Sprinkler (107/20)	Dry switch, Halon ²⁾	
IS-detector ISIF (99/28)	Conventional IS detector or MCP ¹⁾	
IS-detector ISIF (98*/29*)	Conventional IS detector or MCP ¹⁾	

¹⁾ = Steady measuring

²⁾ = Pulsed measuring

* = NOTE! Intrinsically safe ID 98 (DIP 29) is only supported by the CS3000 and CS3004 systems.

** = Door indication is the only ID that does not give alarm.

Connection Examples

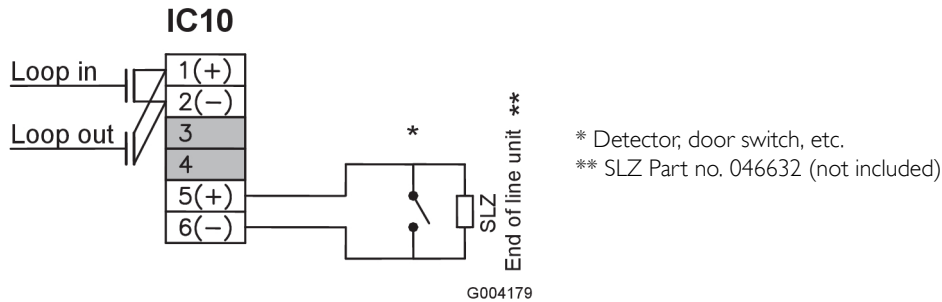

IC10 (Door indication ID code 117)

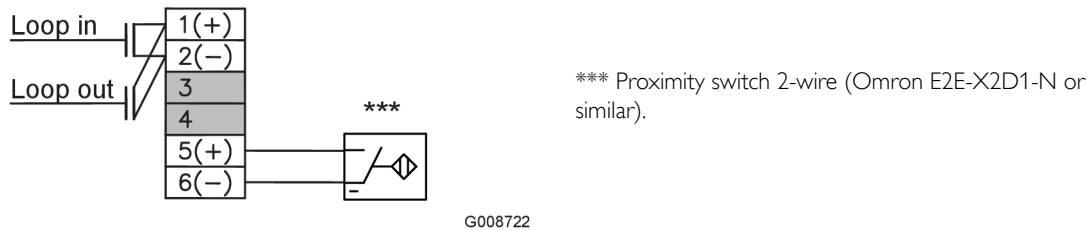

IC10 (IS-detector ID code 99)

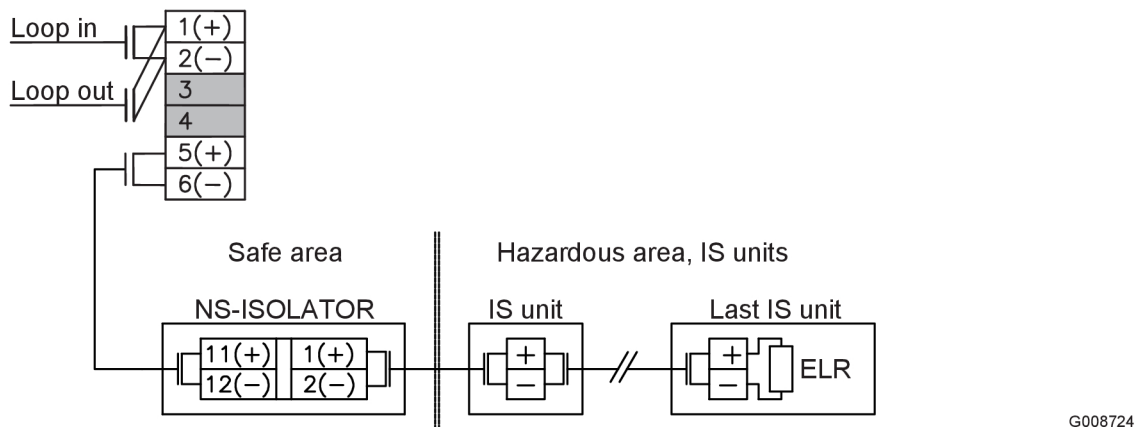

NOTE!

This note applies for IS applications only:

- In the above IS- setup the IC10 shall have ID 99 (SW2 DIP 1-5 settings 28) and can have either low or high current mode (SW2 DIP 6 OFF/ON) enabled depending on the load. If for example a HC100 A2-IS heat detector is connected to the NS-Isolator the IC10 must have high current mode (DIP 6 ON) enabled.
 - With low current mode enabled, use ELR (End of Line Resistor) 33 k Ω .
 - With high current mode enabled, use ELR 6.8 k Ω . In a CS3000 or CS4000 system it is also possible to use ELR 10 k Ω when high current mode is enabled.
- For replacement of the AE-2 series (ID 99) unit in the above IS-setup use IC10 high current mode (DIP 6 ON). ELR value should be 6.8 k Ω (or 10 k Ω if the system is a CS3000 or CS4000).
- For replacement of the AE-2K/I (ID 99) unit in the old AE-2K/I + ES-2K + ZBK-1 setup use IC10 low current mode (DIP 6 OFF) and the ELR should be 10 k Ω .

Dimensions (mm)

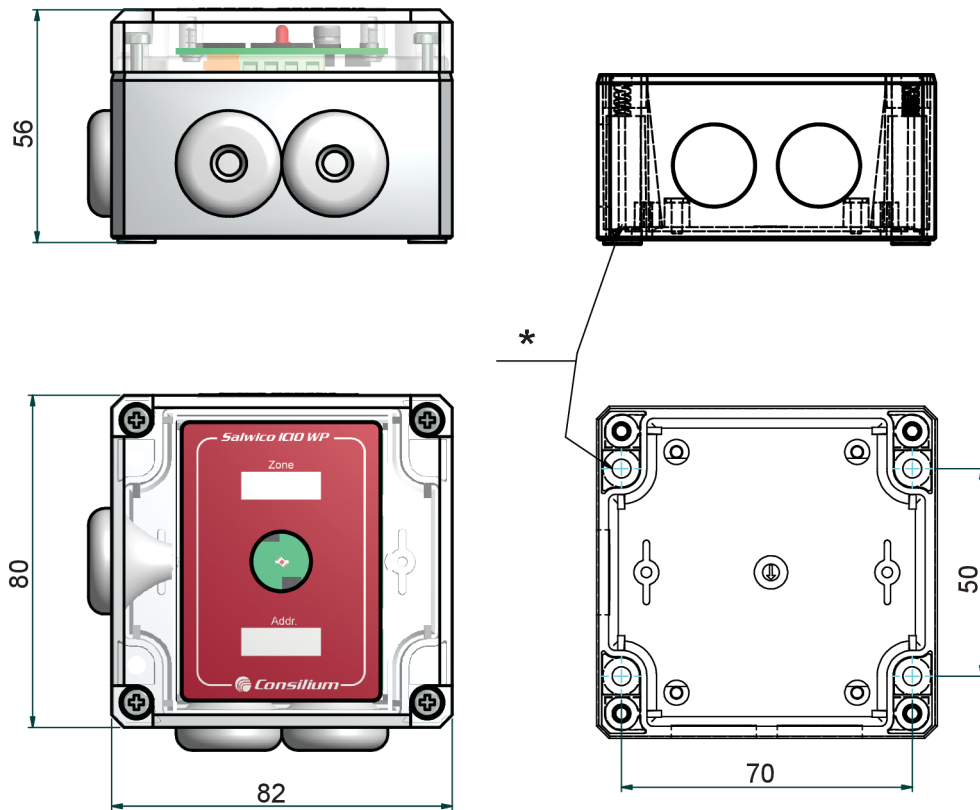

G004183

* Holes for wall mounting (x4): Max screw thread $\varnothing 4$. Max screw head $\varnothing 8$