

G004200

Indication Control Unit

IC44 WPL

Part no. 5200269-00A

System: CS3000, CS4000, TERRA FIRE

General Description

The Indication Control Unit IC44 WPL (equipped with an extra large enclosure) is designed to control and monitor external devices, such as:

- Fire doors
- Fire dampers
- Sprinkler
- Hatches

The control unit is connected to a loop in the same way as other fire alarm loop units and can be used in damp spaces.

The IC44 WPL includes 4 inputs and 4 outputs (2-pole dry changing contacts). The inputs are designed to detect both active input, short and cable break.

The loop address of the IC44 WPL is set by a DIP-switch.

This unit does not require an external 24 VDC separate power supply. High current consumers (i.e. proximity switches) on inputs may need external 24 VDC.



NOTE!

The use of proximity switches requires external 24 VDC supply.

Data

Common data

Inputs	4 inputs for closing contacts or NPN/PNP proximity switches. Local indication available.
Outputs	4 pcs 2-pole relay contacts, max 30 VDC, 1A.
Power output	24 VDC, 80 mA
Loop nominal voltage	35 VDC
Loop working voltage	22 - 38 VDC
Loop current consumption	0.3 mA
Input end of line resistor	30k Ω (Included)
Ingress protection	IP66
Relative Humidity	At low temperature 95% At high temperature 93% \pm 3%
Ambient temperature	-40°C to +70°C
Cable gland	TET M20 for cable \varnothing 8-13mm
Cable terminals	2.5 mm ²
Material	PC/ABS
Colour	Transparent/RAL7035
Weight	760 g
Certified according to	 2531-CPR-232.1738 DOP no. 6301907

Data for external 24 VDC

Nominal voltage	24 VDC
Working voltage	19 - 30 VDC
Max current	100 mA
Nominal power output	24 VDC, 80 mA
Max load on inputs	15 mA per input. Pulsed.

Pulse length inputs 100 ms

Data without external 24 VDC (Loop powered)

Nominal voltage n/a
 Working voltage n/a
 Max current n/a
 Nominal power output n/a
 Max load on inputs 5 mA per input. Pulsed.
 Pulse length inputs 8 ms

IC44 as a Replacement Unit

Table 1. IC44 replaces the following discontinued products

Part no.	Product	Note	SW2 DIP 1-5	SW2 DIP6	SW2 DIP8
046409, 046414, 046415, 046431, 046451, 046414- 6538	CM-2x Control module, in a box		ID 1	*	ON
046411, 046412, 046417, 046441, 046453	CM-4x Control module, in a box		ID 2	*	ON
046432, 046452	CM-2x Control module, for DIN rail	**	ID 1	*	ON
046442, 046454	CM-4x Control module, for DIN rail	**	ID 2	*	ON
046433, 046455	CMK-2x PCB	***	ID 1	*	ON
046443, 046456	CMK-4x PCB	***	ID 2	*	ON

* Set DIP 6 to ON when external 24 VDC power supply is used.

** No replacement available. Please contact your supplier.

*** Casing to be discarded.



NOTE!

Physical dimensions will differ between IC44 and the replaced products.

DIP-Switches

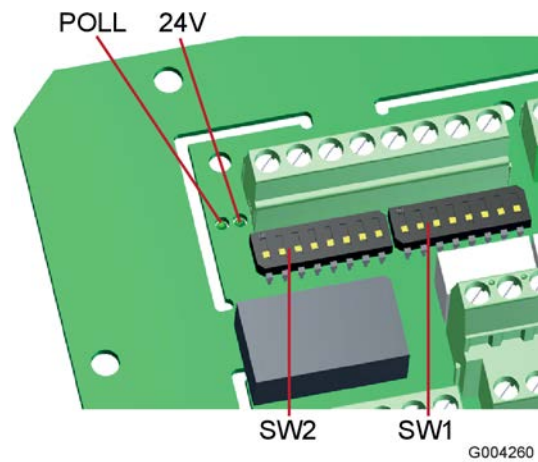

Figure 1. Location of DIP-switches and LEDs on the PCB

The following functions are set by the DIP-switches. (Use a pointed tool of suitable size.)

Address switch SW1

The loop address of the control unit is set by DIP-switch SW1.

Function switch SW2

The following functions are set by the switch SW2:

Table 2. ID for different operation modes set by SW2 DIP 1 to 5

ID	Function	Example
1	2 inputs and 2 outputs	Emulates control unit CM-2x
2	4 inputs and 4 outputs	Emulates control unit CM-4x

Table 3. Different functions set by SW2 DIP 6 to 7

SW2 DIP no.	Function
6	ON Must be set when external 24VDC power supply is used.
7	Not used



CAUTION!

SW2 DIP 8 must always be ON!

Terminals

Table 4. List of terminal connections

Terminal		Connection
	1-12 and 47-50	IN+ IN- SIG IND *
	13-16	+ -
	17	A+
	18	A-
21-22	+ -	Isolated 24VDC output (for local indications). Max 5 mA for local indicators. Note: Only active when external 24VDC input is connected to 13-16.
23-46	C NC NO	Output 1 to 4
	<p>* Local output indication with external resistor. Max load 5 mA.</p>	

Figure 2. Label on PCB

Connection Examples

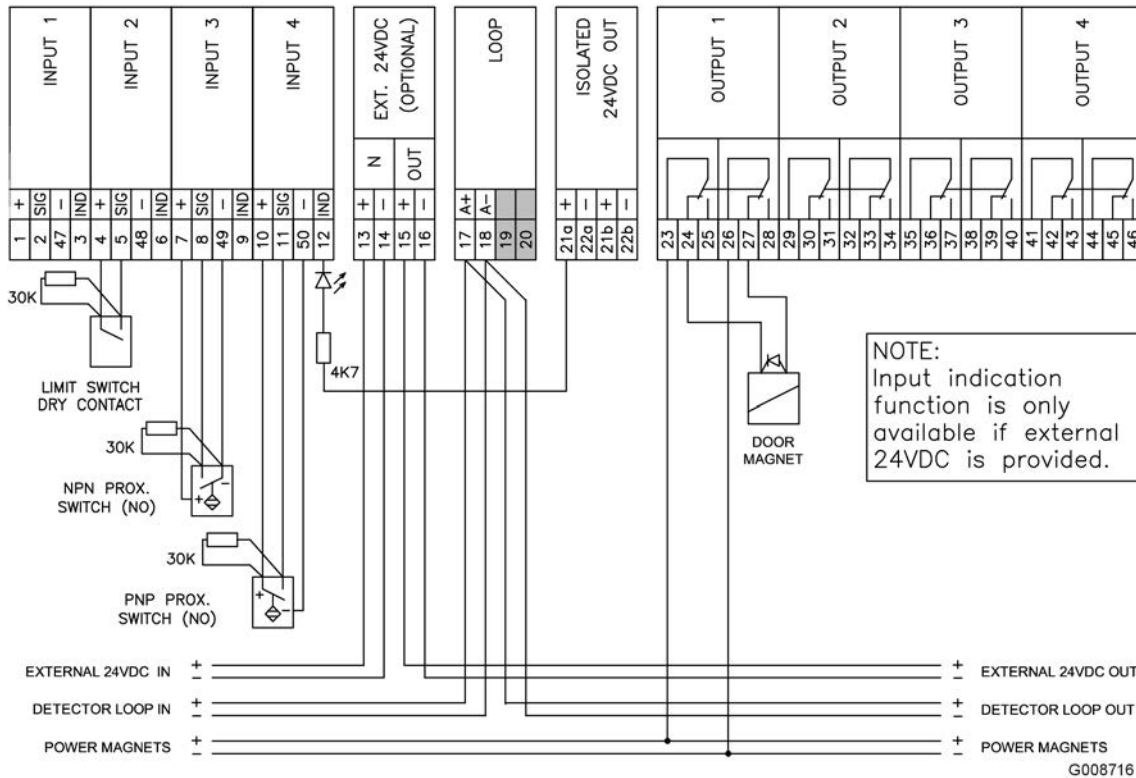

Dimensions (mm)

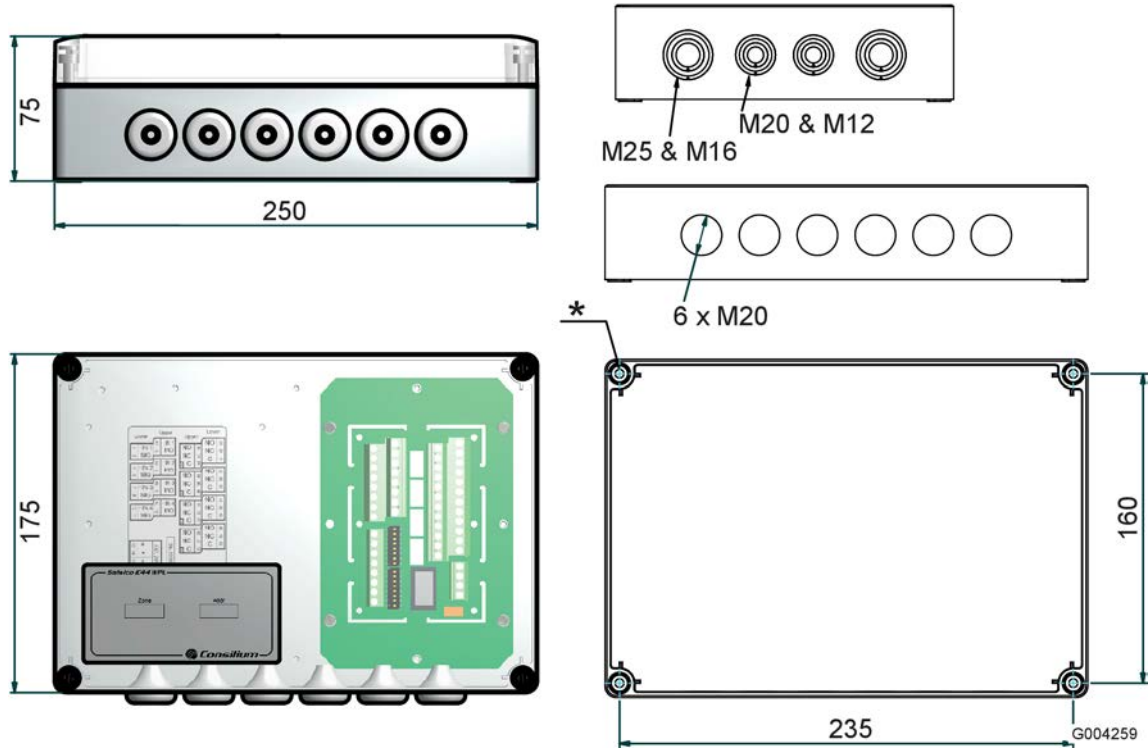

* Wall mounting holes (4x): Seat distance from wall = 10 mm. Max screw thread = 4.5 mm. Max screw head = 8.5 mm.