



G003443

Addressable/Conventional IR Flame Detector

AC-IR-3Fq

Part no. 5200236-00A

System: TERRA FIRE

General Description

The AC-IR-3Fq is a triple frequency infrared flame detector produced using the latest in manufacturing technology. It is supplied with an array of advanced features, making it 'better by design'.

The detector uses infrared elements suitable for the detection of smokeless combustible liquid and gas fires, as well as smoke-forming open fire involving carbonaceous materials as contained in wood, plastics, gases, oil products etc.

The fire evaluation process is done by triple infrared (3Fq) sensor; protected by a sapphire glass filtering $>6.0\mu\text{m}$ wavelength radiation.

The sensor measures the hot carbon dioxide in a specific flame wavelength; the B and C sensors simultaneously measure the interference radiation in near wavelengths.

This technique together with intelligent signal processing through microprocessor and custom algorithms, achieves excellent detection reliability while maintaining the highest immunity to interference radiation and sunlight.

Features

- Triple frequency IR detector
- Low current draw
- Suitable for installation in damp environment
- Easy maintenance
- Remote LED option
- Approved to UNI EN54-10 Ed. 2002

Testing

For functional test, use:

- Salwico IR Test lamp, part no. 5100553-00A

or

- MD9902-TB-A Flame detector test box, part no. 5200820-00A.

It is difficult to test the detector without the IR test lamp or test box due to its high immunity to unwanted alarms.

Test with gas torch

A test with real fire can also be conducted using gaseous combustible, such as butane, propane, LPG etc., by using a gas torch.

Adjust to obtain a flame of about 25cm in length. The detection distance, with Class 3 detector, is about 2 m. To obtain a red flame, it is necessary to partially obstruct the nozzle adjustment air holes.



NOTE!

Correction factor in the table is referred to Ethyl alcohol.

Fuel	Distance correction factor
Ethyl alcohol puriss.	1.0
Petrol (Heptan purum)	1.5
Diesel oil (gas oil)	0.8
Kerosene (jet fuel A1)	1.0
Methyl alcohol purum (Methanol)	0.8
Acetone	1.5

Data

Electrical Specifications Conventional Mode (incl. Base)

Working voltage	14-30 VDC
Working current	0.45 mA
Alarm current	Max 30 mA

Electrical Specifications Addressable Mode (incl. Base)



Working voltage	22-38 VDC
Working current	0.6 mA
Alarm current	1 mA
Current when short circuited	12 mA

Environmental Specifications

Application Temperature Range	-10 °C to +55 °C
Humidity	Up to 95%

Mechanical Information

Height	69 mm (including base)
Diameter	103 mm
Weight	250 g ± 5%
Weight with IP65 Base	380 g ± 5%
Wire Gauge for Terminals	2.5 mm ²
Colour	White RAL9010
Material	Polycarbonate Flame Retarded Cl. UL94V0
IP Rating	Depends on base

Certified according to  0474/yyyy
yyyy = year of production
 (pending)

Detector Base

5200235-00A Salwico AC-IR-3Fq Conventional Base
5200237-00A Salwico AC-IR-3Fq Addressable Base
5100874-00A AC-IR-3Fq Rugged Addressable Base

Test Equipment

5100553-00A Salwico IR Test lamp

Installation

Base alternatives:

- To reach IP65, use conventional or addressable base with bayonet and locking screws.

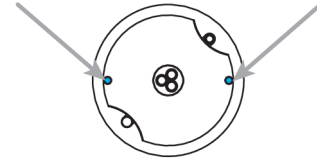

G009840



NOTE!

The plastic covering the screw holes (diaphragm) has to be removed first.

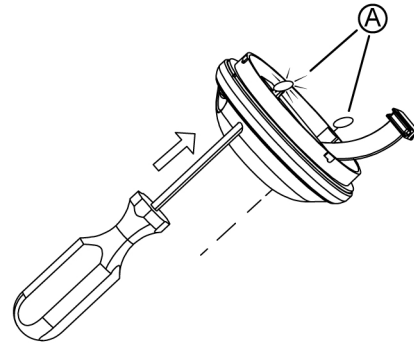

G022876

A) Diaphragm

- To reach IP67 or IP66, use rugged base. Do **not** remove the plastic covering the screw holes (diaphragm) when using this base. If diaphragm is broken, tighten the screw by using a bolt and a washer.

Certain factors need to be considered when designing an installation:

- The sensors should not be mounted exposed to direct or reflected sunlight.
- The sensors should be mounted so that objects do not block their field-of-view (FOV). This includes glass, Plexiglas and other visibly transparent materials. Contact Consilium for more information.
- Whenever possible, sensors should be mounted so their ranges and fields-of-view overlap.
- Sensors should be mounted so their FOV cannot be chopped by moving machinery or human operators during normal operations within the area. Therefore they should be installed as high as possible or on the ceiling.
- The detector window should not be exposed to hot or cold intermittent airflow which could change the temperature of the detector itself or detector FOV background.

- To ensure optimum sensitivity and performance, sensors should be mounted so they do not point directly at hot surfaces: if this is necessary first follow procedure to ensure no chopper is present.
- When monitoring hot spots (eg engine exhaust) the minimum distance should be at least 3 meters. If not possible, move the detectors optical FOV so it is not completely directed towards the hot area to control.
- The sensors should be mounted so that they are easily and safely accessible for inspection and maintenance.
- If mechanical, high-temperature damage, or window contamination is likely to occur in the installed location, the sensor should be protected. However the protection method cannot obstruct the sensors FOV with any material, including visibly transparent materials, such as glass and Plexiglas.
- The sensor can be mounted in any orientation, as long as captive screws are removed or can be removed.
- Mounting the sensor so that it points downwards is recommended as this generally results in minimal window contamination.
- The best form of room monitoring is achieved by mounting the detector high in the corner of the room with detector inclined towards the floor. Angle of inclination of detector axis=45° and lateral angle=45°.
- In the case of ceiling mounting it is necessary to calculate the coverage area according to the installation height. In this installation there can be a slight obstruction of vision by smoke from the fire. For this reason it is advisable that the detector is mounted below the ceiling at about 10% of the room height.
- Care must be taken to avoid that sensor installation exceeds environmental approvals such as temperature, shocks, vibrations.
- Care must be taken to avoid that sensor installation exceeds electromagnetic interference approval: in particular install detectors in places out-of-reach of personnel (including contractors and crew members).
- It is important **NOT** to leave any extra cable slack when installing this detector.
- Cable shield shall be connected to the ground on one side only.

- The DIP-Switch Setting recommended by Consilium is to turn Sw.No.2 ON for the highest sensitivity. For more details, see Settings.

For more details, see Flame Detector Installation manual 5100512.

Angle of Reception

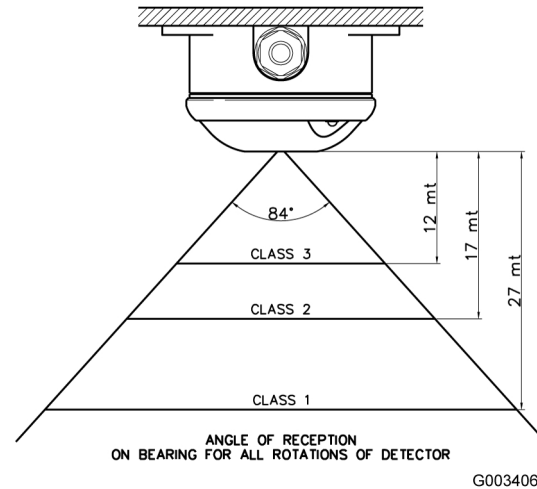

Dimensions (mm)

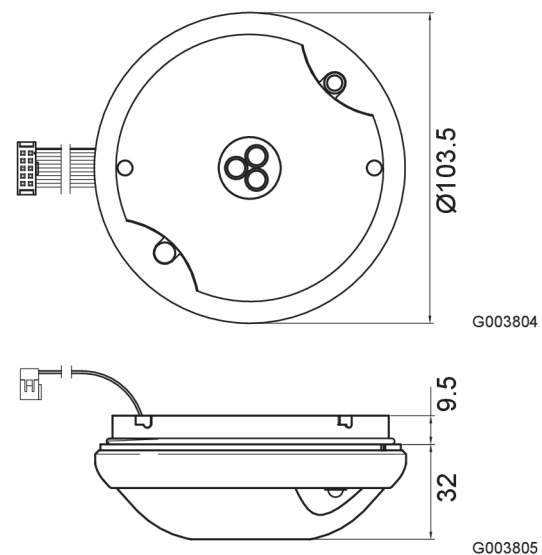

Settings

S1 DIP-Switch setup

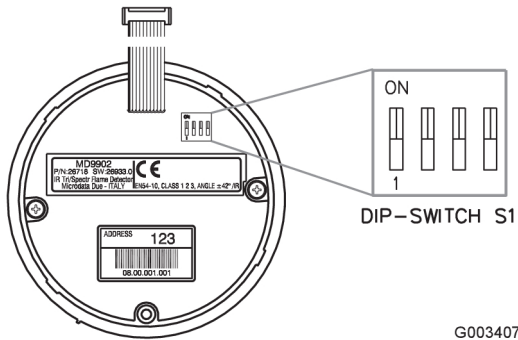

G003407

Figure 1. DIP-Switch Setting.

Use the 4-ways Dip-switch S1 to set the detector as Conventional or Addressable and preset sensitivity threshold (Class). Angle of Reception $\pm 42^\circ$ in all configurations.

Table 1. DIP-Switch Setting

Sensitivity class	Sw.No. 1	Sw.No. 2	Sensitivity
Class 1*	OFF	ON	High, up to 25 m

Directional sensitivity and cover area

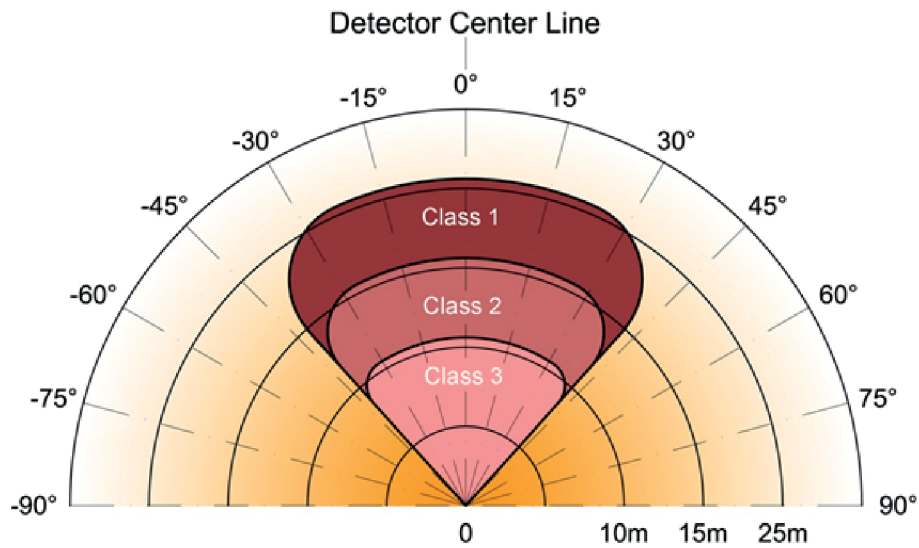

G010721

Sensitivity class	Sw.No. 1	Sw.No. 2	Sensitivity
Class 2	ON	OFF	Medium, up to 17 m
Class 3**	OFF	OFF	Low, up to 12 m

Table 2. Conventional Mode

Mode	Sw.No.3	Sw.No.4
Conventional	ON	ON

Only when used with Base 5200235-00A.

Table 3. Addressable Mode

Mode	Sw.No.3	Sw.No.4
Addressable**	OFF	OFF

Only when used with Base 5200237-00A.

* Recommended setting by Consilium

** Default factory setting