



G004912

System: Salwico Gas Detection

Gas Alarm Panel Module

Control M Gas Internal

Part no. 51 I0001

General Description

The Control M Gas is a control panel with a 4.3" graphical colour display used to manage and supervise a gas alarm system. Control M Gas Internal mounts in the gas alarm cabinet front.

Control M Gas Internal is equipped with communication buses for connecting to the gas alarm system, but it has to be used in connection with module BusCon M Gas.

Features:

- A backlit 4.3" graphical colour display
- Alarm buzzer
- LED status indicators
- Backbone Bus Interface
- MODBUS interface
- USB interface (for service & maintenance)
- One power output
- One alarm output
- One fault output
- Three programmable outputs

Refer to the User Guide for more information on operating Control M Gas.

For details on assembling a system and definitions of common system terms, refer to the Installation Manual.

Data

Operating voltage range	22-48 VDC
Current consumption (at 24V)	92 mA
Ingress protection	IP55
Operating temperature range	-5°C to +55°C
Weight	620 g
Display	4.3", 480×272 pixels, TFT
USB port	USB 1.1 Embedded Host
RS-485 interface	Isolated
1 digital input	24 VDC
5 digital outputs	Relay contacts
1 Power output	19-30 VDC, 0.5 A
Certified according to	 0845/yy yy = year of production

Indicators and Buttons



G004914

Refer to the User Guide for more information.

Addressing

Available addresses for Control M Gas Internal are between 1 and 10.

As a system master controller it must have address 1.

Terminals

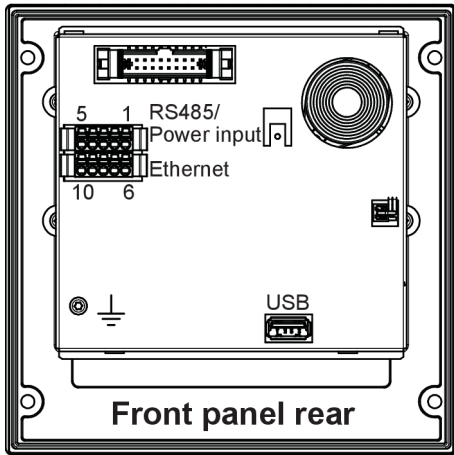

BUSCON M GAS		1	2	3	4	5	6	
ISOLATED SERIAL INTERFACE CHANNEL	PROTECTIVE GROUND							-
	BACKBONE BUS EXTERNAL							D- 55
	BBE RS485, OUT 2							D+ 54
	BACKBONE BUS EXTERNAL							D- 53
	BBE RS485, OUT 1							D+ 52
	POWER INPUT 2							D- 51
	POWER INPUT 1							D+ 50
	22-30VDC							- 49
	POWER OUTPUT							+ 48
	24VDC 0.5A							+ 47
RELAY OUTPUT #4							- 34	
COMMON FAULT							+ 33	
RELAY OUTPUT #3							- 32	
PROGRAMMABLE							+ 31	
RELAY OUTPUT #2							- 24	
PROGRAMMABLE							+ 23	
RELAY OUTPUT #1							- 21	
PROGRAMMABLE							+ 20	
RELAY OUTPUT #5							- 13	
GAS ALARM LEVEL 1							+ 12	
INPUT 1, ALLOCATED FOR POWER BOOST							- 11	
							+ 10	
							- 9	
							+ 8	
							- 7	
							+ 6	
							- 5	
							+ 4	
							- 3	
							+ 2	
							- 1	

G004953

Figure 2. Terminal connections on BusCon M Gas

For detailed terminal information, see datasheet for BusCon M Gas module.

ETHERNET			
ETHERNET Tx	Tx-	10	
=> Only for firmware updates	Tx+	9	
ETHERNET Rx	Rx-	8	
=> Only for firmware updates	Rx+	7	
GROUND, ETHERNET	G	6	

RS485			
POWER INPUT 24VDC	V+	5	
=> Not used	V-	4	
EXTENSION BUS RS485	D+	3	
=> Not used	D-	2	
SIGNAL GROUND, RS485	SG	1	

G004971

Connections

Control M Gas Internal mounts in the front of the central cabinet.

Using ribbon cables connect the Control M Gas to BusCon M Gas.

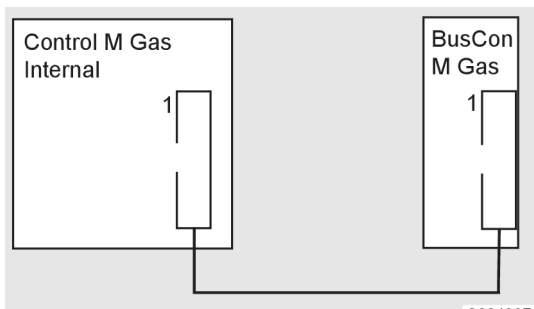

G004967

Figure 1. Control M Gas connected to BusCon M Gas

RS-485 Termination

For RS-485 Termination the built-in terminator (120 ohm) shall be activated with the RS-485 DIP switch located on the rear of the front panel.

For recommendations and examples on RS-485 Termination, refer to the Installation Manual.

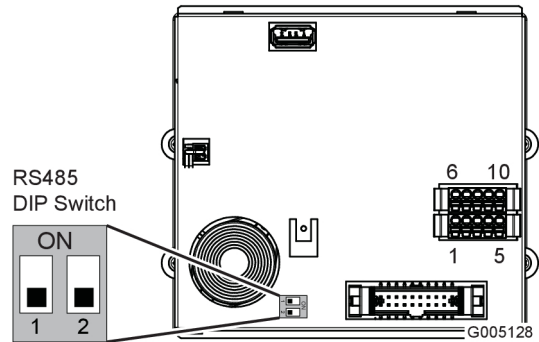

G005128

Table 1. DIP switch for RS-485 Termination

DIP Switch No.	Description	ON	OFF
1	BB1	Active	Deactivated
2	BB2	Active	Deactivated

Module Dimensions (mm)

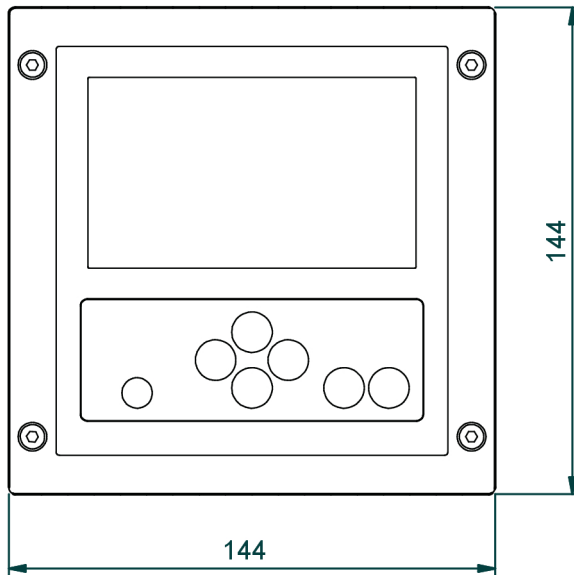

G004973

Mounting Dimensions (mm)

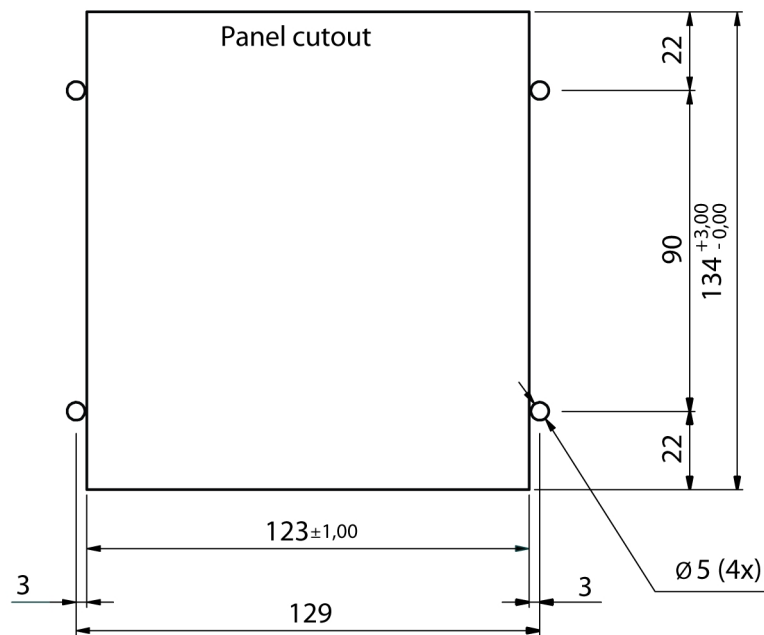

G001730