



G017071

Fire Alarm Cabinet

External Door

Part no. 5100861-00A

System: TERRA FIRE

General Description

The External Door is a fully transparent door with a plexiglass window.

The External Door is intended to be used with either the Fire Alarm Control Panel or the Distributed Cabinet, when they are used as combined Fire brigade / Evacuation - control panel. The External Door replaces then the ordinary door, so that switches, evacuation panel, and other controls are visible through the plexiglass window.

The External Door is supplied with a keylock for Swedish standard key SS3654 to access the interior.

As standard the External Door comes as a right hinged door (opens from the left), however it is possible to change the hinge direction and turn the key lock around to open it from the right.

Accessories

Swedish standard keys SS3654

Data

Ambient temperature	Max 25 °C
Ambient humidity	0 to 95% RH
Material	Stainless steel Polycarbonate (smoked) Plastic door caps
Colour	RAL7035
Weight	3 kg ± 5%
Dimensions (H × W × D)	670 × 440 × 40 mm
Ingress protection	IP30
Certified according to	CE

09 2531-CPR-232.1686
DOP no. 6301900



G017106

Figure 1. Example of a taylormade fire brigade control panel, equipped with the External Door.

Dimensions (mm)

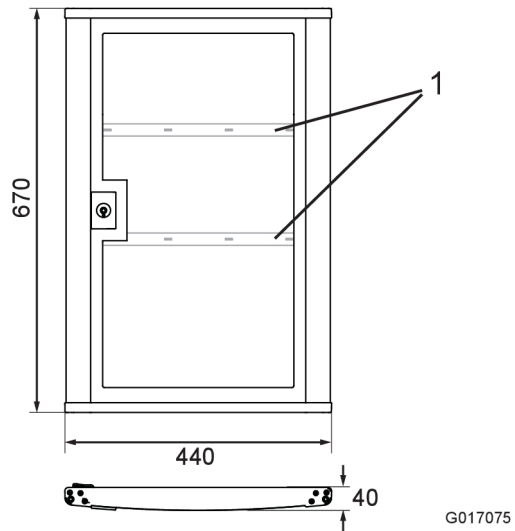

Figure 2. The supporting crossbars (1) can be moved up or down slightly in order to fit the internal equipment.