

G003352

System: CGD50/500, CGS50/500

Surge Prot M H

Part no. 5100420-22A

General Description

Surge Prot has 3 major functions:

- Surge protected power inputs for the Backbone Bus Internal, BBI.
- Terminal board for Backbone Bus External, BBE (RS485 Repeater).
- Electronic short circuit protected outputs for Control or Repeater panels.
Note! This output is not supervised.

These functions can be used together or individually.

The module is designed to be used where there are no requirements for electrical isolation between devices.



NOTE!

The module has built-in terminators for BBI and BBE. See section RS485 Termination for more information.

For details on assembling a system and definitions of common system terms, refer to the Installation Manual.

Data

Operating voltage range	19-30 V DC
Max. supply current – PSU1 IN & PSU2 IN	8 A + 8 A
Max. load current – PSU1 OUT & PSU2 OUT	0.7 A + 0.7 A
Quiescent current consumption (at 24V)	42 mA
Cable terminals	2.5 mm ²
Operating temperature range	-5 °C to +55 °C
Weight (with housing)	115 g ± 5%
Spare part no. (without housing)	5100420-20A
Fuse F101/F102	10A Fast-Acting
Certified according to	



2531/yyyy
yyyy = year of
production

Parts:

Part name	Part no.
Surge Prot module (fully assembled)	5100420-22A
Surge Prot module (delivered as two parts)	5100420-21A
Spare part: PCB module	5100420-20A

Indicators

Surge Prot indicators display input and output status.

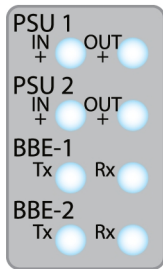

G003351

Indicator	Indicator Colour	Status
PSU 1 IN	Green	OK
	Yellow	Fuse F101 has blown
	None	PSU1 IN supply not present
PSU 1 OUT	Green	OK
	Yellow	PSU1 OUT fault (Output overloaded)
	None	PSU1 IN supply not present, or Fuse F101 blown
PSU 2 IN	Green	OK
	Yellow	Fuse F102 has blown
	None	PSU2 IN supply not present
PSU 2 OUT	Green	OK
	Yellow	PSU2 OUT fault (Output overloaded)
	None	PSU2 IN supply not present, or Fuse F102 blown
BBE-1 Tx - Rx	Green	OK
	None	No communication
BBE-2 Tx - Rx	Green	OK
	None	No communication

Connections

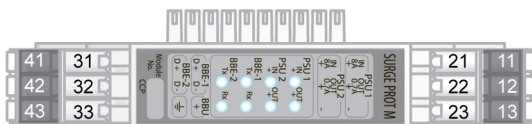

G003354

Connector No.	Function	Description
11	IN 8A+	PSU 1
12	OUT 0.7A+	
13	-	
21	IN 8A+	PSU 2
22	OUT 0.7A+	
23	-	
31	D+	BBE-1
32	D-	
33	+	BBU
41	D+	BBE-2
42	D-	
43		Ground

Connection Board

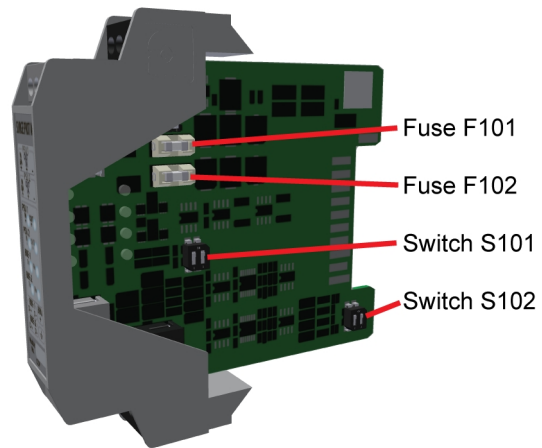

G003353

RS485 Termination

For RS485 Termination the built-in terminator (120 ohm) can be activated with the BBE DIP switch S101 and the BBI DIP switch S102 located on the Connection board (see figure).

For recommendations and examples on RS485 Termination, refer to the Installation Manual.



Table 1. BBE-1 and BBE-2 terminations, DIP Switch S101

DIP Switch No.	Description	ON	OFF
1	BBE-1	Active	Deactivated
2	BBE-2	Active	Deactivated

Table 2. BBI-1 and BBI-2 terminations, DIP Switch S102

DIP Switch No.	Description	ON	OFF
1	BBI-1	Active	Deactivated

DIP Switch No.	Description	ON	OFF
2	BBI-2	Active	Deactivated

Module Dimensions (mm)

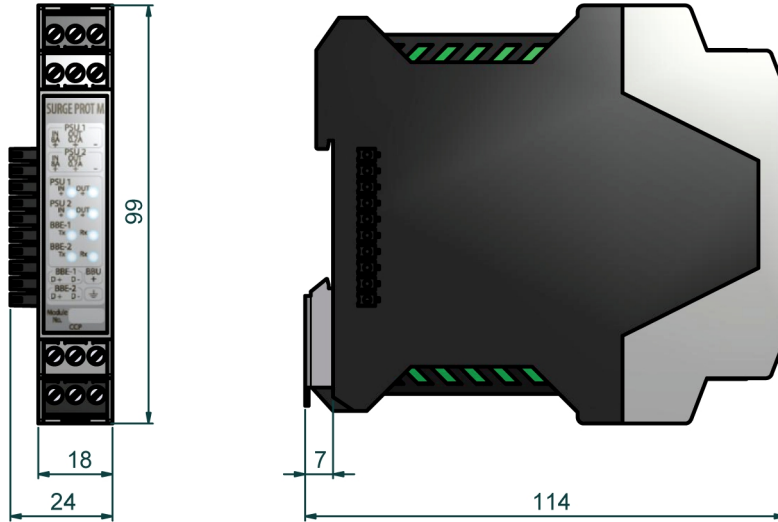

G003349

Mounting

Mount the module on a horizontal 35 mm DIN rail.