



G003441

System: TERRA FIRE

Fire Alarm Central **Cabinet Industrial Compact S**

Part no. 5100167-00A

General description

The central is designed for fire alarm systems, suitable for large industrial buildings, public buildings and hospitals.

This slim wall mounted cabinet has room for one Control Panel M 4.3 and a locked compartment for documents.

The cabinet is approved according to CPD / MED.

For more information about fire alarm systems, refer to the data sheets of system modules and control panels.

Features

- IP65 cable inlet in the top of the cabinet
- 5 mounting points (of which 2 keyhole), M8, in cabinet back
- Light gray RAL7035 as standard colour
- Powder coated 1.25mm aluzinc steel
- Swedish standard fire key lock (SS3654)
- IP30
- Compartment for documents, max. 40 mm thick

For details on assembling a system and definitions of common system terms, refer to the Installation Manual.

Data

Height	670 mm
Width	440 mm
External depth	90 mm
Internal depth	50 mm
Material	Aluzinc coated steel Alu door profiles Plastic door caps and panel

Ingress protection	IP30
Mechanical mounting	M8 bolts (5x)
Colour	RAL7035
Weight	9 kg

Included in cabinet:

Two Swedish standard SS3654 keys

Tools needed for service:

SS36534 fire brigade key
Screwdriver, torx, T10
Screwdriver, torx, T20
Screwdriver, torx, T25
Screwdriver, flat, 3 mm
Screwdriver, hexagon, 4 mm

Dimensions (mm)

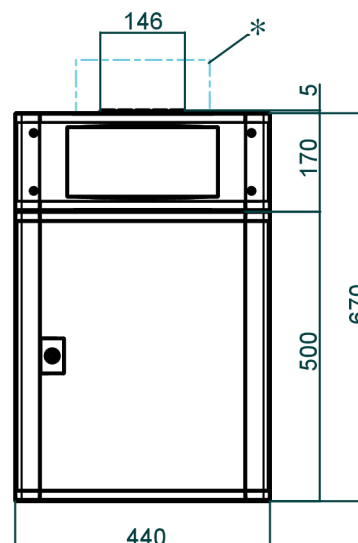

G003432

* = Cable inlet clearance

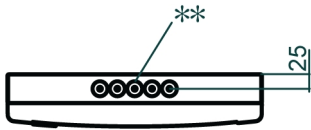

G003433

** = Cable inlet glands, M20 (5x)

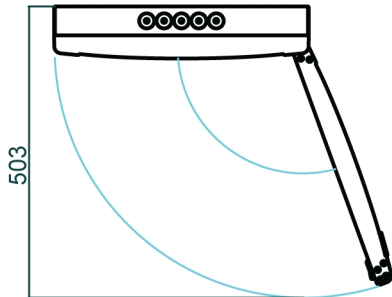

G003434

Mounting

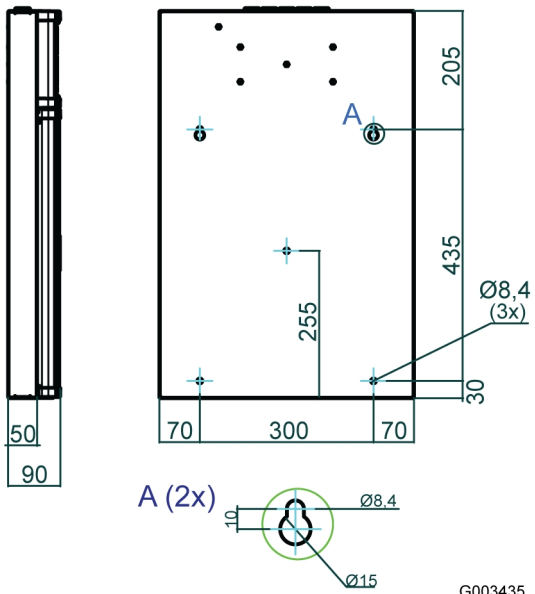

G003435