

GAS DETECTOR ST650EX

PART.NO. 1226000-1226120

DETECTION OF COMBUSTIBLE GASES AND VAPOURS



SYSTEM CGD50, CGD500 TOUCH

GENERAL DESCRIPTION

- Detection of combustible gases and vapours
- All-round industrial gas detector
- ATEX / IECEx
- Touch screen experience, control without additional tools
- Self-diagnostics
- Reliable sensor technology

The **ST650EX** is an all-round gas detector which functions well under the most difficult circumstances. The heart of the detector is a replaceable gas sensor. This sensor is available in various versions, such as a catalytic flammable (CAT) gas sensor, Infrared (NDIR) a Thermal Conductivity sensor (TCD). And a Molecular Property Spectrometer. The sensor has a long life-span, which achieves an optimal cost of ownership.

The **ST650EX** is available with or without a graphic display. The version with a graphic display, shows the measured value and various status notifications locally. The capacitive key control gives you an experience similar to a touchscreen and enables easy navigation through the user/calibration menu. The user menu is secured with a password; unauthorized users cannot access the gas detector. The control of the user/calibration menu does not require additional tools (for example magnets). Simple, easy and user friendly!

The user menu provides different features, such as a zero and span calibration, adjusting alarm set points (local alarm indication through notifications on the display and bright colored LED), showing set points, diagnostic information and simulation of the output signal (4-20mA) for loop testing without gas.

HEIGHTS AREAS / REMOTE APPLICATIONS:

A remote application allows the user to mount the sensor separately from the transmitter. Remote sensors are ideal for applications where the gases present ascend, i.e. gases lighter than air. High located detection areas are often difficult to reach for example during maintenance. When using a remote sensor, the sensor itself will be mounted high and the transmitter will be mounted within close reach. This makes maintenance quick and easy and therefore cost effective. Cable lengths up to 150 meters are supported between the transmitter and the remote sensor (depending on the type).

APPLICATIONS:

- + Chemical industry
- + Refineries
- + Water industry
- + Boiler rooms
- + Storage of packed dangerous substances
- + Food industry
- + Gasturbines
- + Automotive

WE OFFER MORE THAN A PRODUCT!

- + Tailored advice
- + Project advice
- + Technical support
- + Training and education
- + Commissioning
- + Onsite service / maintenance / calibration

ORDERING INFORMATION

GAS DETECTOR								
TYPE	SENSORTYPE	APPLICATION	RANGE	PART NO.				
				STANDARD	REMOTE **	LCD	ALU or RVS***	
ST650EX-CAT 3N	Catalytic	Standard	0-100 %LEL CH ₄ *	1226000	.../R	.../LCD	.../Al	.../SS
		Isobutane	0-100%LEL Isobutane	1226110				
		Hydrogen	0-100%LEL H ₂	1226111				
		Propane	0-100%LEL C ₃ H ₈	1226120				
		Hexane	0-100%LEL C ₆ H ₁₄	1226005				
ST650EX-CAT HT Remote	Catalytic	High Temp.	0-100 %LEL CH ₄ *	n/a	1226015/R	.../LCD	.../Al	.../SS
ST650EX-CAT 18A	Catalytic	Acetylene	0-100 %LEL C ₂ H ₂	12260018	.../R	.../LCD	.../Al	.../SS
ST650EX-CAT 25	Catalytic	Vapours	0-100 %LEL	1226001	.../R	.../LCD	.../Al	.../SS
ST650EX-CAT 41	Catalytic	Ammonia	0-10 %LEL NH ₃	1226002	.../R	.../LCD	.../Al	.../SS
		Kerosene	0-100 %LEL Kerosene	1226010				
		Gasoline	0-100 %LEL Gasoline	1226011				
		Diesel	0-100 %LEL Diesel	1226012				
ST650EX-TCD 6	TCD	Methane	0-100 Vol.% CH ₄ *	1226008	n/a	.../LCD	.../Al	.../SS
ST650EX-NDIR	NDIR	Methane	0-100 %LEL CH ₄ *	1226020	.../R	.../LCD	.../Al	.../SS
		Propane	0-100 %LEL C ₃ H ₈ *	1226021				
		Methanol	0-100 %LEL CH ₃ OH*	1226024				
		Xylene	0-100 %LEL C ₈ H ₁₀	1226025				
		Methane	0-100 %LEL CH ₄ *	1226050				
		Propane	0-100 %LEL C ₃ H ₈ *	1226051				
		Ethanol	0-100 %LEL C ₂ H ₅ OH	1226022				
Hexane	0-100 %LEL C ₆ H ₁₄	1226023	n/a					
ST650EX-MPS	MPS	Methane****	0-100 %LEL	1226080	.../R	.../LCD	.../Al	.../SS

* Standard calibration, other calibrations to be specified when ordered.

** Delivery including 10 mtr gas tubing.

*** Standard delivered in Aluminium (Al) housing.

**** Calibrated for Methane ,True LEL for: Butane, Ethane, Hydrogen, Isobutane, Isobutylene, Isopropanol, Methyl ethyl ketone, Octane, Pentane, Propane, Propylene, Toluene, Xylene.

Note: Catalytic bead sensors are not suitable for areas with reduced oxygen and for environments containing silicones or leaded vapours, **NDIR sensors are more applicable.**

EXAMPLE

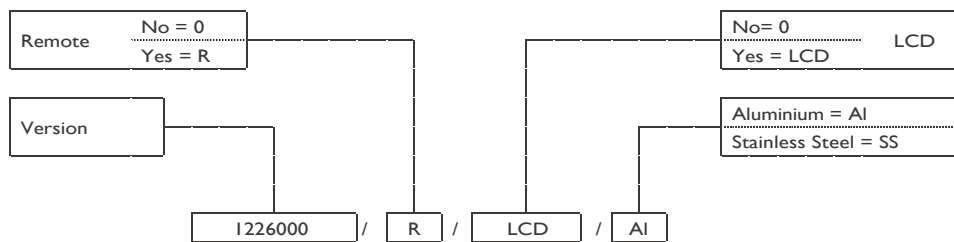

Article no. example: ST650EX-3 remote version, with LCD, aluminium housing: **1226000/R/LCD/Al**

DIFFERENCES IN SENSOR TYPES	CATALYTIC	TCD	NDIR	MPS
Measuring range	up to 100 %LEL	up to 100 Vol.%	up to 100 %LEL & 100 Vol.%	up to 100 %LEL
Resistance to silicone poisoning	No	limited	√	√
Detects Hydrogen	up to 100 %LEL	up to 100 Vol.%	No	up to 100 %LEL
Affected by hazardous chemical environments	Yes	limited	No	No
Detection in anaerobic / inert conditions	No	√	√	Limited
Sensor burn-out at high concentrations	Yes	No	No	No
Sensor lifetime	long	long	ultra-long	ultra-long
True LEL	No	No	No	Yes

The specifications described herein are subject to change without notice.



Standard version



LCD version



Remote / LCD version

ACCESSORIES

TYPE	IMAGE	PART NO.	DESCRIPTION
Signal cable		4002427	4 core shielded cable, 4x0,75 mm ² (flexible cores, 3+PE), per meter
Duct mounting set		4002723	Duct mounting set for mounting in ventilation ducts
Splash guard		4002712	Environmental sensor protection, incl. splash water
Inline flow adapter		4002720	Inline flow adapter for sample applications, connection 2x6mm, SS
Protective hood		4002714	Protective hood SS, for optimal sensor protection in "wet" production areas, dim. 315x300x138 mm
Isolation set EMC/RFI		4002440	Isolation plate EMC/RFI, 160x160 mm
Protective bracket		4002713	SS bracket, extra protection for use in e.g. warehouses
Conical collector hood		4000657	Conical hood for ascending gases
GasWizard USB cable		4002763	GasWizard USB/RS485 programming cable

The specifications described herein are subject to change without notice.

SPARE PARTS / CONSUMABLES

SPARE GAS SENSOR	PART NO.	RANGE	DESCRIPTION
Type CAT 3N	1212200	0-100 %LEL CH ₄	Gas sensor for standard applications
Type CAT 3S	1212201	0-100 %LEL CH ₄	Gas sensor for standard applications
Type CAT HT	9220032	0-100 %LEL CH ₄	High temperature, applications up to 120°C ambient temperature
Type CAT 18A	1212206	0-100 %LEL C ₂ H ₂	Gas sensor for Acetylene
Type CAT 25	1212203	0-100 %LEL C ₃ H ₈	Gas sensor for combustible vapours containing halogens (VCM)
Type CAT 41	1212204	0-100 %LEL Gasoline 0-100 %LEL Kerosene 0-10 %LEL NH ₃	Gasoline applications, range 0-100 %LEL Kerosene applications, range 0-100 %LEL Ammonia applications, range 0-10 %LEL
Type TCD 6	1212205	0-100 Vol.% CH ₄	Thermal Conductivity sensor, measurements up to 100 Vol.% CH ₄
Type NDIR CH ₄	1219622	0-100 %LEL CH ₄	Infrared sensor (NDIR), Methane
Type NDIR CH ₄	1219622/V	0-100 %LEL CH ₄	Infrared sensor (NDIR), Methaan (remote only)
Type NDIR C ₃ H ₈	1219623	0-100 %LEL C ₃ H ₈	Infrared sensor (NDIR), Propane
Type NDIR C ₃ H ₈	1219623/V	0-100 %LEL C ₃ H ₈	Infrared sensor (NDIR), Propane (remote only)
Type NDIR C ₂ H ₅ OH	1219624/V	0-100 %LEL C ₂ H ₅ OH	Infrared sensor (NDIR), Ethanol
Type NDIR C ₆ H ₁₄		0-100 %LEL C ₆ H ₁₄	Infrared sensor (NDIR), Hexane
Type NDIR CH ₃ OH		0-100 %LEL CH ₃ OH	Infrared sensor (NDIR), Methanol
Type NDIR C ₈ H ₁₀		0-100 %LEL C ₈ H ₁₀	Infrared sensor (NDIR), Xylene
Type NDIR CH ₄	1219624/V	0-100 Vol.% CH ₄	Infrared sensor (NDIR), Methane
Type NDIR C ₃ H ₈	1219625/V	0-100 Vol.% C ₃ H ₈	Infrared sensor (NDIR), Propane
Type MPS	1219700	0-100 %LEL	True LEL Sensor*

Note: Catalytic bead sensors are not suitable for environments containing silicones or leaded vapours, NDIR sensors are more applicable.

*Calibrated for Methane, True LEL for: Butane, Ethane, Hydrogen, Isobutane, Isobutylene, Isopropanol, Methyl ethyl ketone, Octane, Pentane, Propane, Propylene, Toluene, Xylene.

TEST GASES AND ACCESSORIES

TYPE	PART NO.	DESCRIPTION
BUGAS, 1,0Vol.% CH ₄	9990501	Methane, 1,0Vol.% in air; 110 gas liters
BUGAS, 2,2Vol.% CH ₄	9990502	Methane, 2,2Vol.% in air; 110 gas liters
BUGAS, 50Vol.% CH ₄	9990533	Methane, 50Vol.% in air; 110 gas liters (only applicable for Busens D, type 6TCD)
BUGAS, 0,85 Vol.% C ₃ H ₈	9990547	Propane, 0,85 Vol.% in air; 110 gas liters
BUGAS, 2,0Vol.% H ₂	9990506	Hydrogen, 2,0Vol.% in air; 110 gas liters
BUGAS, 20,9% O ₂ / N ₂	9990537	Synthetic air, 20,9% O ₂ / 79% N ₂ , 110 gas liters
Calibration adapter	4002715	Stainless Steel calibration flow adapter
Gas hose	1225819	Flexible tubing, Ø 6mm, per meter
Flow regulator	9990600	Flow regulator Chrome/brass, fixed flow 0,5 l/min
Flow regulator	9990601	Flow regulator Stainless Steel, fixed flow 0,5 l/min

Consilium offers a wide range of test gases, if the required test gas is not listed, please contact us.

CONNECTION DIAGRAM GAS DETECTOR

ST650EX used as 4-20mA transmitter (3 wires):

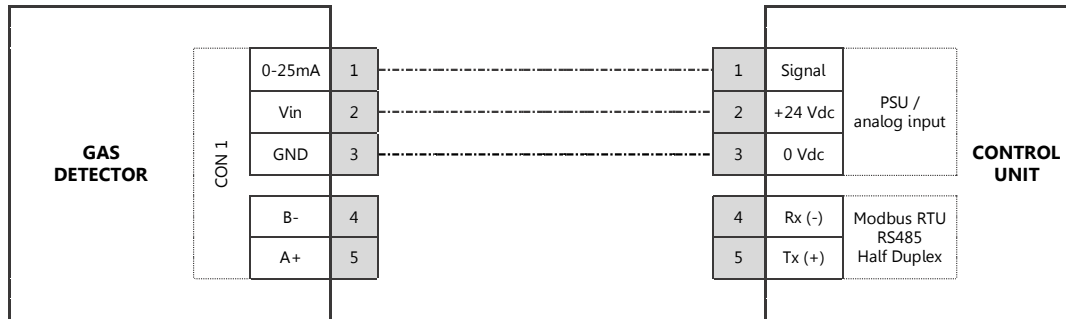

ST650EX used as MODBUS slave device:

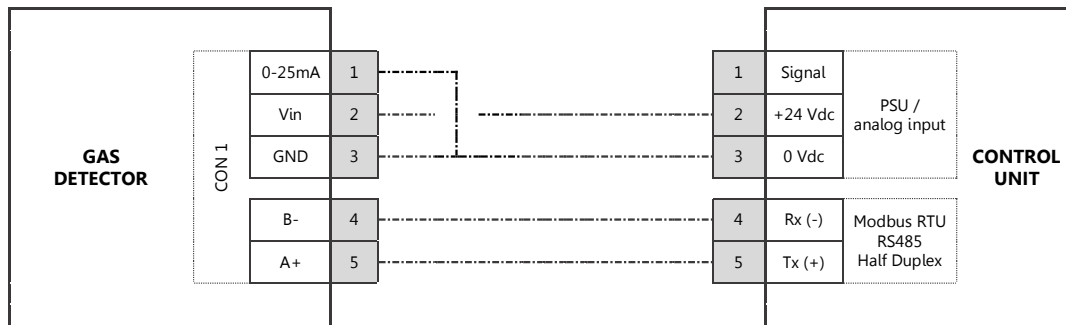

ST650EX used as MODBUS slave device and 3 wire 4-20 mA transmitter:

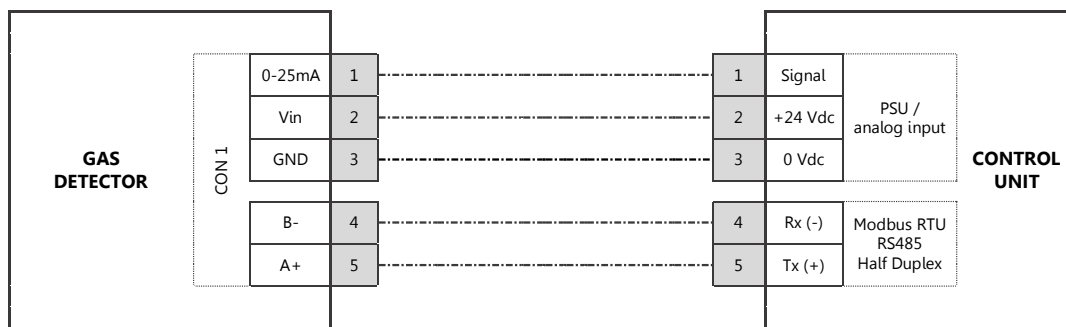

DIMENSIONS

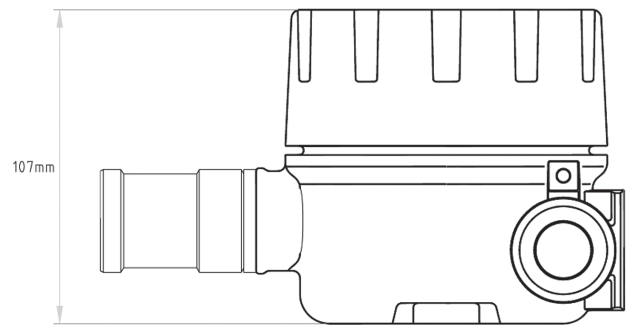
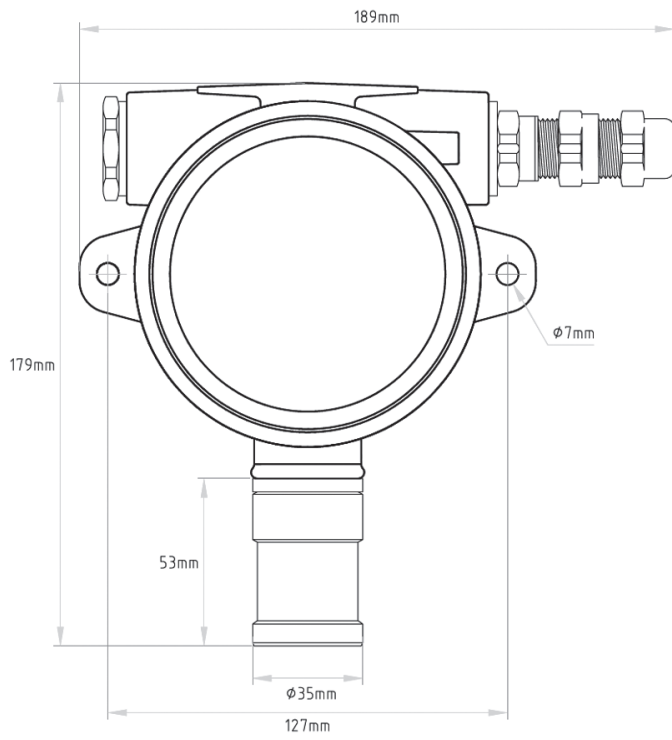

SPECIFICATIONS

PRODUCT	ST650EX						
Gas type	Combustible gases and vapours						
Calibration	Standard Methane, also available for Propane, Butane, Hydrogen, Methanol, Ethanol, Kerosene, Gasoline, Toluene, Hexane, Ammonia, Acetic acid and more... (calibration to be specified when ordered)						
Sensor type	Catalytic bead sensor (CAT), Infrared (NDIR), TCD, MPS						
Display (optional)	Digital graphic display with backlight						
Status LED display	Green: OK, Red: Alarm, Yellow: SF (System Failure), Blue: User menu active						
Power supply	18 - 30VDC (max. 120 mA)						
Outputs	Analogue: 4-20 mA (2 mA system failure, >20 mA overrange) Digital: RS485 Modbus RTU (half-duplex)						
Signal cable	3-wire shielded, 0.75 ... 2.5 mm ² (excluding earth connection and Modbus)						
Cable gland	Standard Brass, optional SS (thread M20x1.5)						
Load impedance	max. 400 Ω at 24VDC						
Operating temperature	-20 to +60 °C, remote HT -20 to +120 °C						
Relative humidity	15-95 % (non-condensing)						
Pressure range	700 to 1300 hPa (type 3) 800 to 1200 hPa (type IRs)						
Enclosure	Aluminum with coating, optional SS						
Dimensions	179 x 189 x 107 mm (HxWxD)						
Weight	Aluminum: 1,3kg Stainless Steel: 2,55kg, Aluminum LCD: 1,75kg Stainless Steel LCD: 3kg						
Ingress Protection	IP 66 (Sensor IP 6x)						
Enclosure gas sensor	SS 316						
CE marking	ATEX (Directive 2014/34/EU) Electromagnetic Compatibility (Directive 2014/30/EU)						
Approvals	<table border="0"> <tr> <td>ATEX</td> <td>Compact/remote: II 2G Ex db IICT6 Gb II 2D Ex tb IIIC T85°C Db</td> <td>Remote HT: II 2G Ex db IICT3 Gb II 2D Ex tb IIIC T200°C Db</td> </tr> <tr> <td>IECEx</td> <td>Compact/remote: Ex db IICT6 Gb Ex tb IIIC T85°C Db</td> <td>Remote HT: Ex db IICT3 Gb Ex tb IIIC T200°C Db</td> </tr> </table>	ATEX	Compact/remote: II 2G Ex db IICT6 Gb II 2D Ex tb IIIC T85°C Db	Remote HT: II 2G Ex db IICT3 Gb II 2D Ex tb IIIC T200°C Db	IECEx	Compact/remote: Ex db IICT6 Gb Ex tb IIIC T85°C Db	Remote HT: Ex db IICT3 Gb Ex tb IIIC T200°C Db
ATEX	Compact/remote: II 2G Ex db IICT6 Gb II 2D Ex tb IIIC T85°C Db	Remote HT: II 2G Ex db IICT3 Gb II 2D Ex tb IIIC T200°C Db					
IECEx	Compact/remote: Ex db IICT6 Gb Ex tb IIIC T85°C Db	Remote HT: Ex db IICT3 Gb Ex tb IIIC T200°C Db					
Type examination	EN 60079-29-1:2016, EN 50270:2015, EN 50271:2010						
Manufacturer	Consilium Safety Netherlands BV						

