



G021970

# Heat Detector

## **Salwico HC100 A2**

Part no. 038000

System: C300, C308, C316, CS3000, CS3004, CS4000,  
NSAC-1, Salwico Cargo, Salwico Cruise, Salwico Workboat,  
Salwico Yacht

### General Description

The HC100 A2 is a conventional heat detector. The detector is with its low profile and smooth design very suitable in locations with high architectural requirements such as offices, restaurants, hotel rooms and cabins.

The heat sensing element is of thermistor type with a short response time to changes in the ambient temperature. Alarms are optically indicated until they are reset on the central.



The detector is environmentally adapted in aspects of the selection of material and design.

The detector is polarisation independent (unless the remote output is used) which simplifies the installation. The mesh is very easy to change and clean which simplifies maintenance.

### Data

Function	Conventional
Working voltage	16-30 VDC
Alarm temperature	57 °C
EN54 Heat Classification	A2
Working current	< 25 µA
Alarm current	Max 54 mA
Remote output	Max 20 mA
Ingress protection	IP43/55 depending on base
Ambient humidity	95% at 55 °C
Temperature range	-10 °C to +70 °C
Material	PC/ABS
Colour	White
Weight	95 g ± 5%

### Certifications

MED	Certified according to: EN 54-5:2017/A1:2018 IEC 60092-504:2016 IEC 60533:2015  2531/yy yy = year of production DoC no: DOC-004786
CPR	Certified according to: EN 54-5:2017/A1:2018  DoP no. DOC-000526

For information about suitable base plates, see separate document "Base matrix".

## Connection

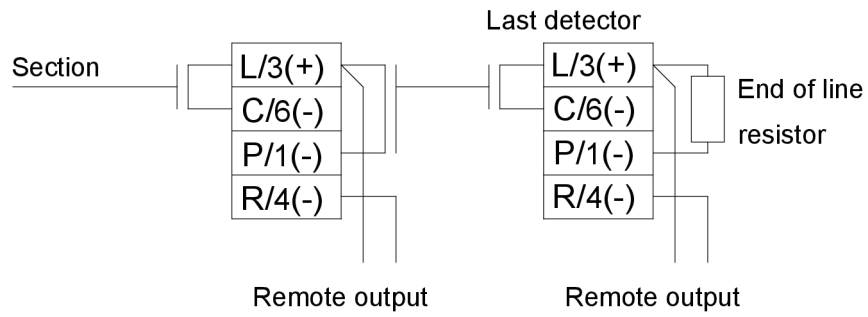

G021971

## Dimensions (mm)

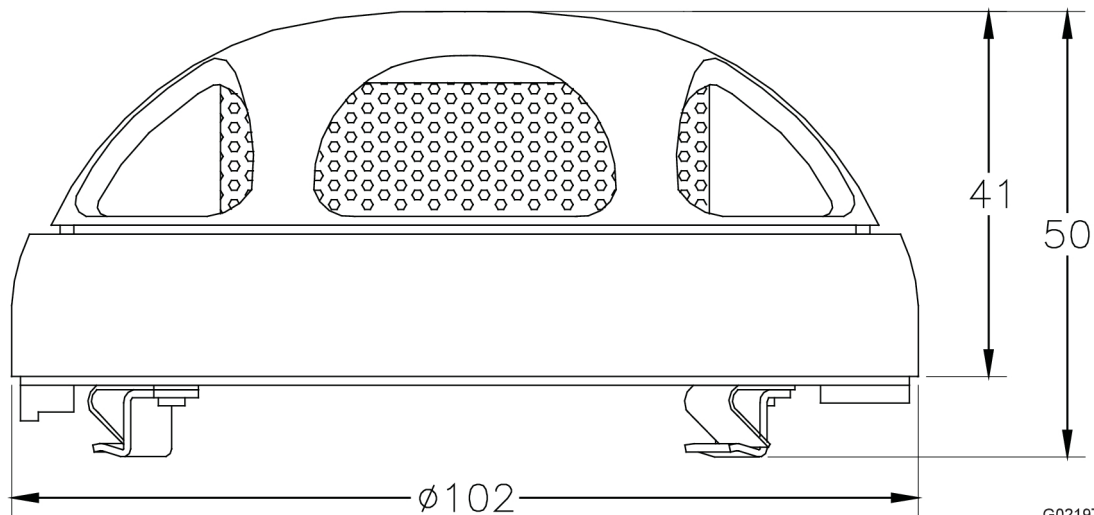

G021972